



General Description:

Using HuaJing's proprietary planar design and advanced NPT technology, the 1200V NPT IGBT offers superior conduction and switching performance, high avalanche ruggedness and easy parallel operation.

Features:

- NPT Planar technology, Positive temperature coefficient.
• Low saturation voltage: Vce(sat), typ=2.6V @Ic=15A, Vge=15V
• Extremely enhanced avalanche capability

Applications:

Power switch circuit of induction cooker.

Absolute Maximum Ratings

(Tc= 25°C unless otherwise specified):

Table with 4 columns: Symbol, Parameter, Rating, Units. Rows include VCES, VGES, IC, ICM, IF, IFM, PD, TJ, Tstg, and TL.

Table with 3 columns: Parameter, Value, Unit. Rows include VCES (1200 V), IC (15 A), PD (186 W), and VCE(SAT) (3.0 V).

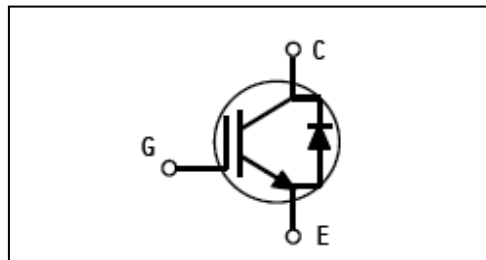
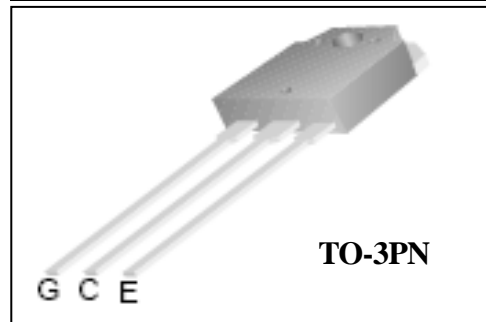

Thermal Characteristics

Table with 5 columns: Symbol, Parameter, Typ., Max., Units. Rows include thermal resistance parameters RθJC and RθJA.

**Electrical Characteristics of the IGBT** (Tc= 25°C unless otherwise specified):

<b>OFF Characteristics</b>						
Symbol	Parameter	Test Conditions	Rating			Units
			Min.	Typ.	Max.	
V <sub>CES</sub>	Collector-to-Emitter Breakdown Voltage	V <sub>ge</sub> =0V, I <sub>ce</sub> =1mA	1200	--	--	V
I <sub>CES</sub>	Collector-to-Emitter Leakage Current	V <sub>ge</sub> =0V, V <sub>ce</sub> =V <sub>ces</sub>	--	--	1.0	mA
I <sub>GES(F)</sub>	Gate to Emitter Forward Leakage	V <sub>ge</sub> =+30V	--	--	+250	nA
I <sub>GES(R)</sub>	Gate to Emitter Reverse Leakage	V <sub>ge</sub> =-30V	--	--	-250	nA

<b>ON Characteristics</b>						
Symbol	Parameter	Test Conditions	Rating			Units
			Min.	Typ.	Max.	
V <sub>CE(sat)</sub>	Collector-to-Emitter Saturation Voltage	I <sub>c</sub> =15A, V <sub>ge</sub> =15V	--	2.6	3.0	V
V <sub>GE(TH)</sub>	Gate Threshold Voltage	I <sub>c</sub> =15mA, V <sub>ce</sub> =V <sub>ge</sub>	3.5	--	7.5	V

Pulse width  $t_p \leq 380\mu s$ ,  $\delta \leq 2\%$

<b>Dynamic Characteristics</b>						
Symbol	Parameter	Test Conditions	Rating			Units
			Min.	Typ.	Max.	
C <sub>ies</sub>	Input Capacitance	V <sub>ce</sub> =30V, V <sub>ge</sub> =0V, f=1MHz	--	4063	--	pF
C <sub>oes</sub>	Output Capacitance		--	415	--	
C <sub>res</sub>	Reverse Transfer Capacitance		--	215	--	

<b>Resistive Switching Characteristics</b>						
Symbol	Parameter	Test Conditions	Rating			Units
			Min.	Typ.	Max.	
t <sub>d(ON)</sub>	Turn-on Delay Time	V <sub>ce</sub> =600V, I <sub>c</sub> =15A, R <sub>g</sub> =10Ω, Resistance Load	--	33	--	ns
t <sub>r</sub>	Rise Time		--	75	--	
t <sub>d(OFF)</sub>	Turn-Off Delay Time		--	182	--	
t <sub>f</sub>	Fall Time		--	96	--	
Q <sub>g</sub>	Total Gate Charge	V <sub>ce</sub> =600V, I <sub>c</sub> =15A, V <sub>ge</sub> =15V	--	188	--	nC
Q <sub>ge</sub>	Gate to Emitter Charge		--	18	--	
Q <sub>gc</sub>	Gate to Collector Charge		--	65	--	



Diode Characteristics						
Symbol	Parameter	Test Conditions	Rating			Units
			Min.	Typ.	Max.	
$V_{FM}$	Diode Forward Voltage	$I_F=15A$	--	1.2	2.7	V
$t_{rr}$	Reverse Recovery Time	$I_F=15A, di/dt=200A/uS$	--	1580	--	ns
$Q_{rr}$	Reverse Recovery Charge		--	15	--	$\mu C$
Pulse width $t_p \leq 380\mu s, \delta \leq 2\%$						

<sup>a1</sup>: Repetitive rating; pulse width limited by maximum junction temperature

Package Information:

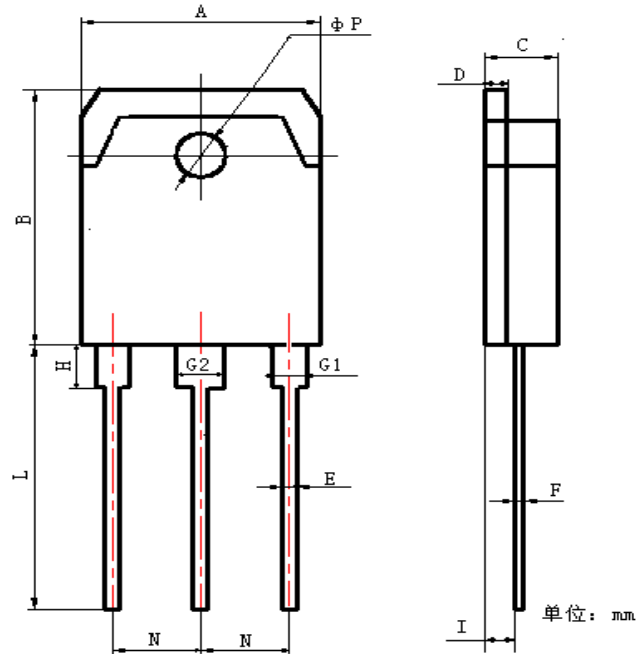

Unit:mm

Item	Range(mm)	
	MIN	MAX
A	15.10	15.90
B	19.30	20.30
C	4.70	4.90
D	1.40	1.60
E	0.90	1.10
F	0.50	0.70
G1	2.00	2.20
G2	3.00	3.20
H	3.30	3.70
I	1.05	1.25
L	19.5	20.9
N	5.25	5.65
$\phi P$	3.10	3.30



The name and content of poisonous and harmful material in products

Part's Name	Hazardous Substance					
	Pb	Hg	Cd	Cr(VI)	PBB	PBDE
Limit	≤0.1%	≤0.1%	≤0.01%	≤0.1%	≤0.1%	≤0.1%
Lead Frame	○	○	○	○	○	○
Molding Compound	○	○	○	○	○	○
Chip	○	○	○	○	○	○
Wire Bonding	○	○	○	○	○	○
Solder	○	○	○	○	○	○
Note	○: means the hazardous material is under the criterion of SJ/T11363-2006. ×: means the hazardous material exceeds the criterion of SJ/T11363-2006.					

Warnings

1. Exceeding the maximum ratings of the device in performance may cause damage to the device, even the permanent failure, which may affect the dependability of the machine. It is suggested to be used under 80 percent of the maximum ratings of the device.
2. When installing the heatsink, please pay attention to the torsional moment and the smoothness of the heatsink.
3. VDMOSFETs is the device which is sensitive to the static electricity, it is necessary to protect the device from being damaged by the static electricity when using it.
4. This publication is made by Huajing Microelectronics and subject to regular change without notice.

WUXI CHINA RESOURCES HUAJING MICROELECTRONICS CO., LTD.

Add: No.14 Liangxi RD. Wuxi, Jiangsu, China      Mail: 214061      <http://www.crhj.com.cn>  
Tel: 0510-85807228      Fax: 0510-85800864

Marketing Part:      Post: 214061      Tel / Fax: 0510-85807228-3663/5508  
E-mail: sales@crhj.com.cn      0510-85800360 (Fax)

Application and Service: Post: 214061      Tel / Fax: 0510-85807228-3399 / 2227  
E-mail: apply@crhj.com.cn